

**PROCEEDINGS OF THE SYMPOSIUM ON DRIP IRRIGATION IN
HORTICULTURE WITH FOREIGN EXPERTS PARTICIPATING**

September 30-th to October 4-th, 1980

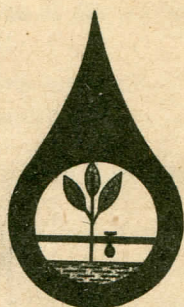

Edited by

K. Slowik, D. Swietlik, K. Sitton

SKIERNIEWICE, POLAND

ENERGY AND WATER SAVING IRRIGATION SYSTEMS IN SPECIAL CROPS

E. Moser ^{1/}

ABSTARCT. Irrigation with micro-jets and drip emitters is becoming increasingly important both in arid and in temperate regions. These new techniques necessitate the need for optimal utilization of water and energy-saving distribution methods. In temperate areas, the use of these techniques is mainly for irrigation of orchards, vineyards and hops.

The knowledge of flow regime in the laterals and particularly in the micro-jets and drip emitters serves as the base upon which such irrigation systems can be planned. Of particular importance are the influence of pressure head, water temperature, water quality, and manufacturing precision of the emitter discharge rate and distribution pattern of each of the various models. Low reliability of some emitters due to clogging of the flow path with mineral and organic matter, chemicals and microorganisms remains a problem.

Economic surveys of irrigation systems have revealed that microjet and drip irrigation not only afford considerable reductions in water and energy consumption, but also that equipment costs are lower than those of comparable systems.

Research has shown that the manufacturing industry is capable of developing irrigation systems which function even under difficult conditions. Science and industry have to continue their efforts to increase reliability and to provide adequate control systems.

INTRODUCTION

Limited availability of water for use in agriculture and increasing energy costs connected with the supply and distribution of water require the development of processes which allow an economical application of water.

Artificial water distribution by surface or gravity irrigation is still common in many countries, particularly in developing countries. Among other things, this method has the disadvantage of high water consumption. Sprinkler irrigation, on the other hand, has better water usage and requires less manual labour, but due to the rain-like distribution of droplets, this method has much higher energy requirements than surface irrigation.

The aim of efficient water and energy utilization is best fulfilled by micro-jet and drip irrigation, which provide limited water application over a defined area, /Goldberg et al. 1976, Rosegger et al. 1976/.

^{1/} Verfahrenstechnik für Intensivkulturen Institut für Agrartechnik Universität Hohenheim
Stuttgart, B.R.D.

Compared with conventional sprinkler systems, considerable energy savings are possible due to the low pressure head. By adjusting the water application to crop and soil conditions, seepage and evaporation losses are kept low and water utilization optimal. Additionally, the low kinetic energy of the drops of water prevents crop damage and soil erosion, particularly on sloping ground.

With the optimal control of water application, both in time and quantity, the vegetation period can be shortened and the product quality improved, /Gustafson 1975/. A further advantage of drip irrigation is that the application is selective and can be programmed to plant needs. This effect becomes particularly noticeable if fertilizer is applied at the same time. As a direct result there is less weed growth and herbicides can be used sparingly. Within certain limits these methods also allow the use of saline water. Increased soil salinity then only occurs along the outer edge of the irrigated zone or wetting front /Goldberg 1970/.

A further advantage is that for crops with large row spacings, such as orchards, equipment costs of drip and particularly micro-jet irrigation systems are lower than those of permanent sprinkler systems.

As opposed to other agricultural crops, special crops place high demands on this irrigation method. Due to their high value, it is essential that they have a constant discharge from each dripelement or an even spray pattern from each micro-jet. These conditions are to be met independent of ground contours and temperature to prevent over or under application of water and sometimes fertilizer.

The largest problem of drip irrigation is the lack of reliability of the system, in particular against clogging of individual drip emitters. This requires intensive equipment inspection because clogging of subsurface systems can lead to dehydration or even loss of plants. In addition, the laterals, which are normally laid on the ground, as well as the drip emitters and the micro-jets can be a hindrance to the use of cultivators or harvesters and are liable to be damaged by these equipment.

STRUCTURE AND FUNCTION OF DRIP AND MICRO-JET IRRIGATION

The most important components of drip and micro-jet irrigation systems are, apart from the water supply, the head unit, the laterals, and the drip emitters or micro-jets. The head unit controls discharge, regulates fertilizer input, filters the water, and if necessary, reduces the main pressure to a given pressure head. Discharge can be controlled automatically with soil moisture or evaporation sensors.

Pipes of PE and PVC-types have proven to be suitable for laterals. When using drip emitters, pressure head is reduced to nearly 0 bars and water is emitted in drops. Micro-jets are driven at pressures between 0,5 and 3 bars, and the water emitted as a spray or jet.

The flow regime and various characteristic coefficients are known or have been experimentally determined in the last few years. The design parameters of the hydraulics of such systems can now be calculated /Gilaad and Marco 1976, Karmeli and Keller 1975, Moser and Sinn 1978/. However, due to low pressure, the pressure loss in the laterals and topographical conditions deserve special consideration.

DRIPPER AND MICRO-JET DESIGNS

Despite the wide variety of designs, drip emitters can be classified in three basic groups: long-path, orifice and porous pipe emitters. Micro-jets can be divided into fixed head and rotation head types. These subdivisions are based on the method of pressure distribution, in the case of drip emitters and the method of water distribution in the case of micro-jets.

During the past five years, 30 different drip emitters and micro-jets have been tested by the Institute of Agricultural Engineering at the University of Hohenheim. The results of these tests will be discussed in the following sections / I-Pai Wu and Gitlin 1977/. For this purpose various irrigation methods are compared with regard to the influence of pressure head, temperature, manufacturing precision, water quality, discharge rate, and the distribution pattern of micro-jets as well as equipment costs and energy and water requirements.

Long-path drip emitter

In the long-path emitter, pressure dissipation occurs in straight or spiral capillaries /fig. 1/. The capillary can be incorporated into the wall of the lateral, be situated inside the lateral, be part of the lateral itself, or be attached to the lateral.

At pressures between 0,1 and 2,5 bars the discharge rates per emitter are from 0,5 to 9 l/h. The cross section of the capillary is between 0,8 and 1,2 mm², in some cases even up to 3 mm², and therefore, relatively large. The length of the long-path emitter depends on the design on the pressure head.



The relationship between pressure head and discharge rate of an emitter is normally described by the equation $q = c \cdot h^m$, where q is discharge, c is discharge coefficient, h is pressure, and m is the characteristic value of the emitter. For long-path emitters, m -values between 0,51 and 0,98 have been determined. Values near 1 indicate laminar flow and those near 0,5 indicate turbulent flow. Due to varying discharge rates, cross sectional shapes and areas, and directions of flow, the critical Reynolds number, i.e. the range of laminar and turbulent flow, is different from that of the flow in straight tubes. An m -value of 0,08 or close to 0 has been determined for pressure equilibrating long-path emitters. This effect is achieved by deforming a flexible membrane which leads to variable emitter lengths.

Orifice, porous pipe and combination drip emitters

Orifice emitters dissipate pressure in a nozzle-like opening in the lateral or in integrated emitters /fig. 2/. In the porous pipe emitters, pressure is dissipated in the pores of the lateral pipe wall and in combination drippers both in a capillary and at the orifice.



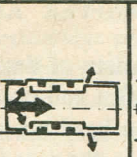
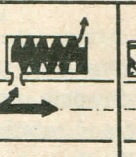
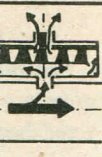

Pressure head range and discharge rate of the orifice emitters are equivalent to those of the long-path emitters. The cross section of their opening is very much smaller though, being between 0,2 and 0,6 mm².

Some porous pipe and combination emitters operate at slightly lower pressure heads but attain the same discharge rates as other emitter types. The m -value of orifice

Systems					
	Long - path - Emitter				
Data					
Pressure head p (bar)	0,25 – 2,5	0,1 – 2,5	0,1 – 2,5	0,1 – 2,5	1,0
Emitter - discharge q (l/h) *	0,85 4,6	1,3 9,0	1,2 7,5	0,55 6,50	4,0
Cross section F_1 (mm ²) l_1 (m)	● 1,2 6,2	● 0,8 0,62	■ 1,0 1,26	■ 1,0 0,77	▲ 0,8 0,5
Emitter - discharge - pressure: ($q = c \cdot h^m$) m	0,730	0,668	0,554	0,779	0,081

* Temperatur of water $\vartheta = 11 \pm 1^\circ\text{C}$

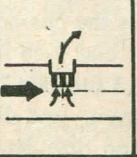
Figure 1. Function and technical data of long-path emitters

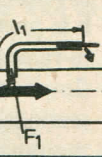
Systems					
	Orifice - Emitter			Porous - Pipe	Comb. - Em.
Data					
Pressure head p (bar)	0,1 – 2,5	0,5 – 3,0	0,1	0,05 – 0,30	0,05 – 0,50
Emitter - discharge q (l/h) *	0,4 – 2,6	0,7 – 8,5	4,0	** 0,35 – 1,80	2,1 – 9,5
Cross section F_1 (mm ²) l_1 (m)	● 0,198 —	* 0,6 —	● 0,4 —	$8 \cdot 10^{-7}$ —	△ 0,8 0,42
Emitter - discharge - pressure: ($q = c \cdot h^m$) m	0,591	—	0,062	0,884	0,643

* Temperature of water $\vartheta = 11 \pm 1^\circ\text{C}$, ** l/m·h

Figure 2. Function and technical data of orifice emitters, porous pipe and combination drippers

emitters is between 0,35 and 0,65 and therefore in the turbulent range and that of porous pipe and combination emitters is between 0,65 and 0,8. The m-value of the pressure equilibrating orifice emitters was measured at 0,062.

Micro-jets

Micro-jet sprinklers normally consist of two parts, namely the base and the distributor. Nozzle or tube shaped flow sections in the base determine the discharge rate, and the distributor determines by what means the water is applied. Despite the same pressure head, micro-jets, as opposed to drip emitters, do not apply the water in drops but in a rain-like spray /fig. 3/. The higher discharge and larger nozzle cross sections increase reliability and allow the use of less expensive filters. For certain crops e.g. strip or surface covering crops, this method of application can have specific advantages for both crop and soil and be more economical than drip irrigation.

Fixed head micro-jets can distribute the irrigation water either in individual jets or as a spray in different geometric patterns*/fig. 3/. In rotating head micro-jets, either the whole distributor unit or a part of it rotates and applies a single jet of water in a spiral shape over a full 360°.

Within a pressure range of 0,5 to 3,0 bars and at cross sections between 0,5 and 4 mm² the discharge rate is between 13 and 245 l/h. The m-value of micro-jets is between 0,43 and 0,53. As in the case of drip emitters, the constant discharge rate at varying pressures is achieved with elastic deformation of the cross sectional area. With micro-jets placed at ground level, a diameter of throw between 0,8 and 4,7 m can be attained.

Systems							
	Fixed head sprinkler				Rotating head sprinkler		
Geometric pattern form	Single jet		Spray		Single jet		
Pressure head p (bar)	0,5 - 2,5	0,5 - 2,5	0,5 - 2,5	0,5 - 2,5	>1,0	>1,0	0,5 - 3,0
Micro-jet discharge q (l/h) *	13,3-219,0	13,6-219,0	13,1-219,0	13,7-219,0	40 - 120	40 - 120	114 - 245
Diameter coverage a (m)	0,9 - 4,4	0,8 - 3,4	1,5 - 4,7	0,9 - 3,4	0,9 - 2,4	1,7 - 3,5	1,1 - 2,1
d (mm)	0,8 - 2,3	0,8 - 2,3	0,8 - 2,3	0,8 - 2,3	-	-	2,3
F ₁ (mm ²)	0,5 - 4,15	0,5 - 4,15	0,5 - 4,15	0,5 - 4,15	0,96 - 3,12	0,96 - 3,12	4,15
d _{add} (mm)	-	-	-	-	-	1,5 - 2,0	-
Number Cross section F ₀ (mm ²)	9 	12 	2 	2 	1 	2 	6
Micro-jet discharge - pressure (q = c · h ^m) m	0,529	0,520	0,533	0,532	0,01 - 0,19	0,03 - 0,12	0,432

* Temperature of water T = 13° ± 1°C

Figure 3. Function and technical data of micro-jets

PERFORMANCE OF DRIP EMITTERS AND MICRO-JETS

Discharge rate versus pressure head

Usage and performance of drip emitters and micro-jets cover the range of irrigation systems up to low volume rotating-head sprinklers /fig. 4/. The influence of pressure head on discharge rate is graphically illustrated by the slope of the drip emitter and micro-jet performance curves. In a double-logarithmic scale the slopes for drip emitters are between 0,5 and 1 and those for micro-jets around 0,5. These differences are due both to design and flow regime of the individual systems. In both irrigation systems, constant discharge rates independent of pressure head are achieved by elastic deformation of membranes. Then the performance curve is horizontal above a certain operating pressure.

The effect of a considerably higher discharge from drip emitters at decreasing pressure is also due to elastic deformation. This so-called cleaning effect flushes out foreign matter at the beginning and end of each irrigation run and thereby helps prevent clogging.

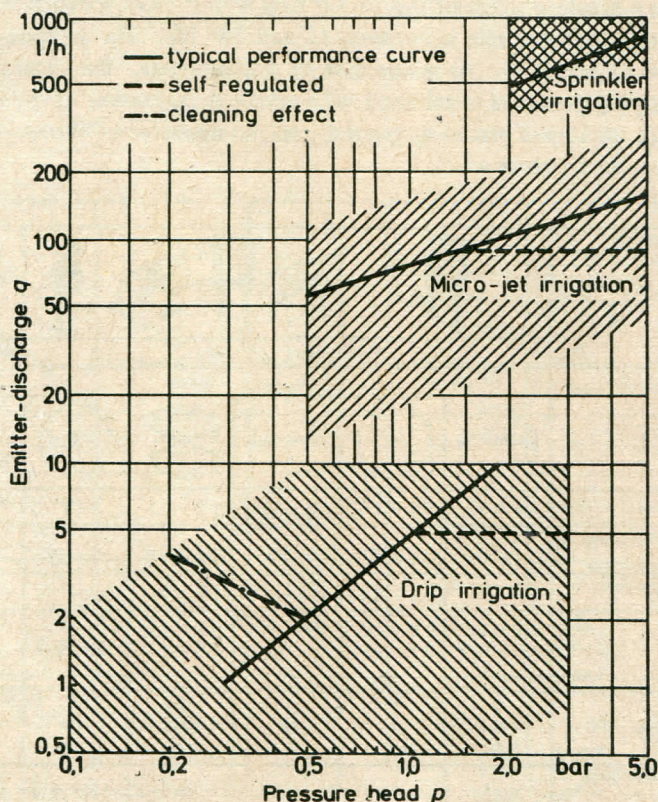

Figure 4. Performance and operation of drip elements, micro-jets and sprinklers

Discharge rate versus temperature

Depending upon the type of emitter, the water and emitter temperature influence the discharge rate to a greater or lesser degree /fig. 5/. A temperature increase from 8 to 60° C will cause little change in the discharge rate of orifice emitters because of turbulent flow conditions. In long-path emitters, however, where laminar flow and a large influence of water viscosity as a function of temperature exists, the discharge rate increases up to 50 %. The porous pipe emitters show increases of up to several times the original discharge rate. Tests have also shown that considerable deviations from these rules occur and are caused by the influence of temperature on the elasticity of the emitter material.

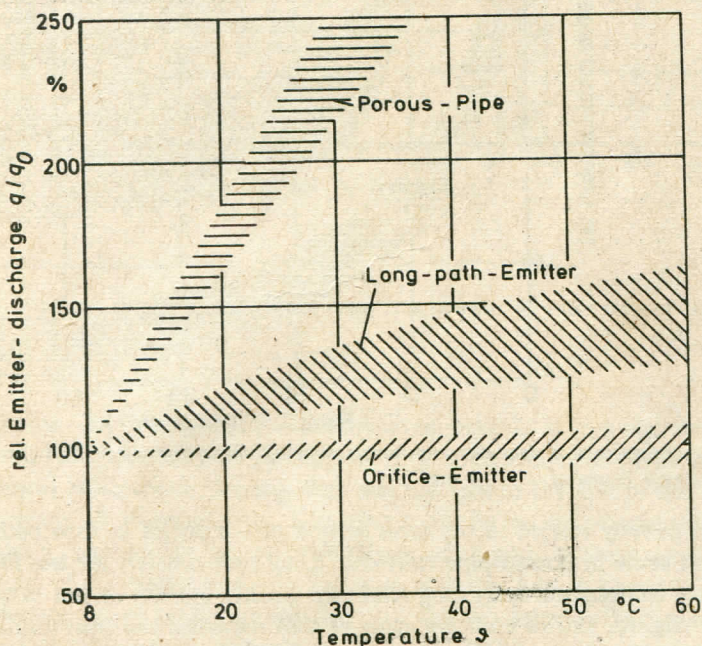

Figure 5. Discharge rate of drip elements versus temperature

Discharge rate versus water quality and clogging

The major problem facing drip irrigation systems is the low reliability of the drip emitters. Reliability is dependent on the content of foreign matter in the water and the design of the emitter / Moser at al. 1979 , Ford and Tucker 1975/. Mineral particles, dissolved chemicals which can crystallize or precipitate and organic materials from bacteria and other microorganisms can slowly clog the drip emitters. Mineral particles are the most common cause of clogging.

Tests with tap water, to which 250 g of quartz sand per cubic meter of water were added, and with particle sizes up to 0,1 mm diameter, showed that clogging begins after a relatively short period of usage /fig. 6/. These values are equivalent to the average particle concentration and distribution in river water which has passed a 150 mesh filter.

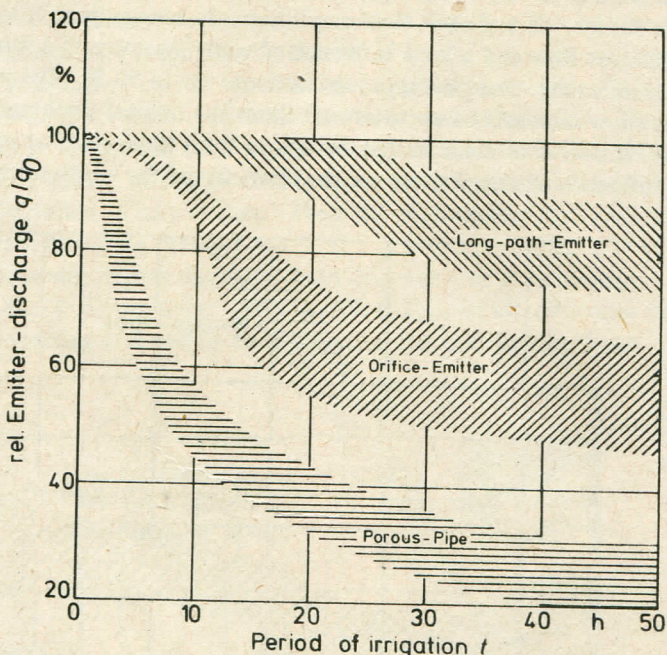

Figure 6. Discharge rate of drip elements versus mineral content of water /250 g/m³ particle diameter = 0,1 mm /

Clogging is directly related to the cross section of the orifice or flow path and is therefore most acute in porous pipe emitters. Long-path emitters are less likely to clog. Orifice emitters normally clog relatively quickly but not as fast as porous-pipe emitters /fig. 6/. Orifice emitters made of thin materials can even display an increased discharge with usage, due to abrasion and the resulting increase of the orifice diameter.

A similar effect can be expected from chemical reactions and the subsequent ageing process of dissolved salts, particularly iron – and calciumhydrogen - carbonate and pH values of 7 to 9.

The effect of water with an iron content of 30 mg per liter and pH value of 7,5 on the clogging of several drip irrigation systems through chemically compounded ochre is shown in figure 7.

To simulate operating conditions the test apparatus, to which were connected various long-path and orifice emitters, was turned on and off periodically. During the operating period, ochre reduces the discharge rate. During the down period the ochre dries out, which again increases the cross section, so that the initial discharge rate of the next operating period rises. It can also be assumed that some ochre would be flushed out of the emitter, which would cause an increase of

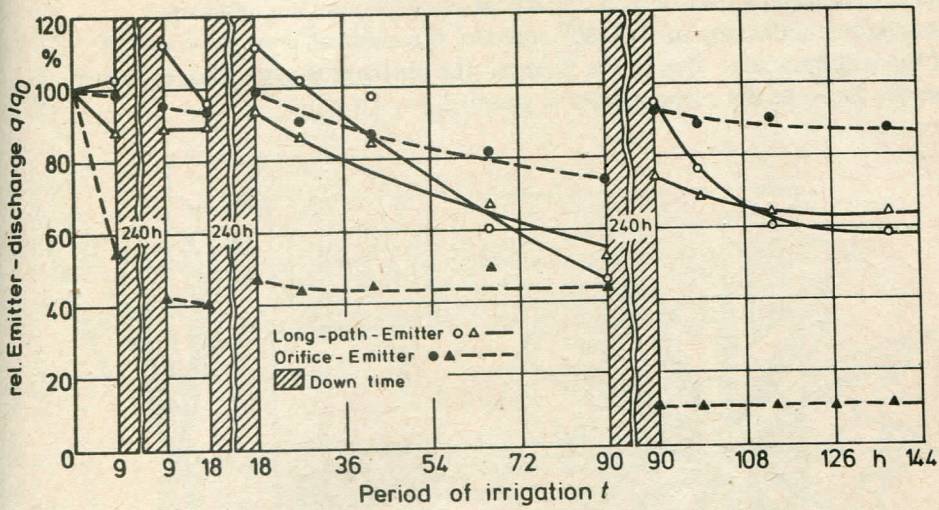

Figure 7. Discharge rate of drip elements versus iron content of water /30 mg Fe/l, pH 7,5 /

initial discharge. At the beginning of an operating period, it can also happen that ochre flakes of sufficient size block emitters with a relatively small cross section, thereby causing more severe clogging than was the case at the end of the last operating period. It seems though, that after a certain period of time and frequency of operation, a constant but not uniform degree of clogging is maintained.

The danger of the clogging of drip irrigation systems through bacterial waste is hard to estimate, since small concentrations of this substance suffice to ensure continued production of this bacterial waste / Ford 1978/. For example a concentration of divalent iron compounds of only 3 mg per liter of irrigation water is sufficient for bacterial iron to produce waste.

DISTRIBUTION PATTERN OF MICRO-JETS

The distribution pattern of micro-jets is worthy of increased attention since, depending upon crop and production methods, a constant distribution and a definite spray pattern of 360°, 280°, 180° or 40° are required. The relevant parameters are: the design of the distributor, in particular the size, shape and number of openings; water pressure or ejection speed of the water and droplet

size; as well as the placing of the micro-jet relative to the irrigated surface.

Figure 8 shows the distribution pattern of single jets over a 360° area and that of a spray over a strip $2 \times 20^\circ$ at equal pressure and discharge. Distribution uniformity of the 360° sprinkler is considerably worse than that of the strip-sprinkler. Due to the fluidics, the discharge is approximately equal but the throw of the strip-sprinkler is greater.

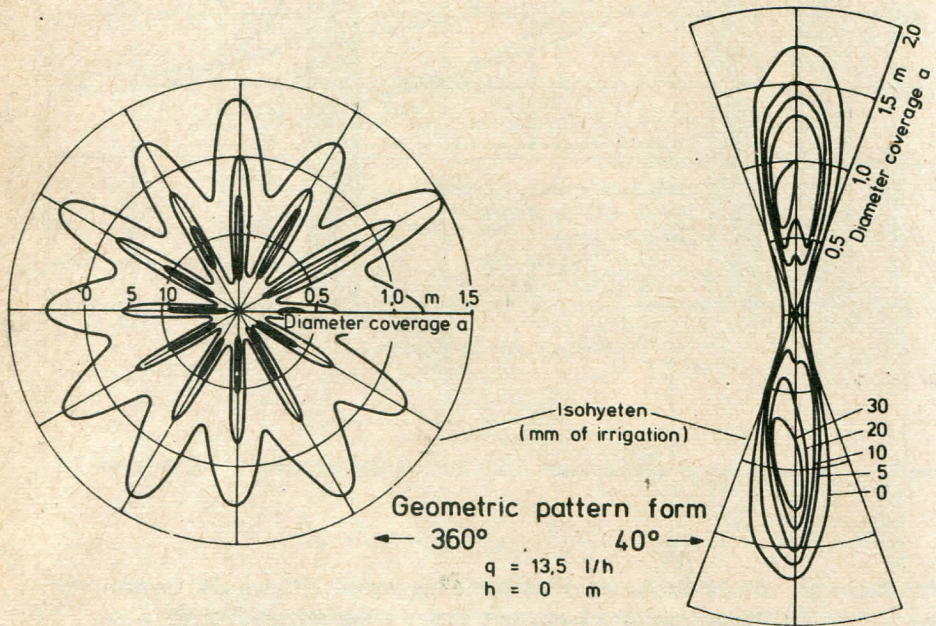

Figure 8. Distribution pattern of micro-jets

WATER AND ENERGY REQUIREMENTS

The present international situation makes energy and water consumption of irrigation methods crucial. By using drip or micro-jet irrigation methods, energy requirements can be reduced to about 20 or 30 % of those of conventional sprinkler systems. The energy savings are achieved through lower pressure head, less pressure loss due to lower flow velocity, and lower discharge rates. Water consumption of the individual methods is dependent on climate and soil and can be reduced by micro-jet or drip irrigation methods to about 50 %. This is a result of the localized application of small amounts of water, which represent the plant physiological optimum, and lower evaporation and seepage losses.

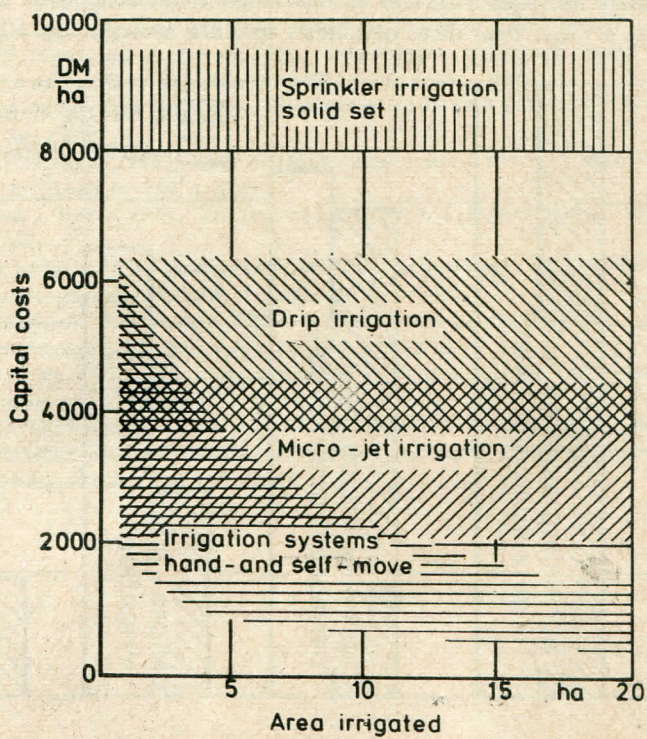

Figure 9. Energy and water requirements of irrigation systems

COSTS

A cost analysis or cost comparison of competing irrigation methods is pointless, not only because of the rapidly changing energy situation and the different water prices in each country but also because of the varying crops, plant spacings, soils and climatic conditions. Depending on type and layout, equipment costs of drip and particularly micro-jet irrigation systems in the Federal Republic of Germany are about 50 % lower than those of solidset sprinkler systems /fig. 10/.

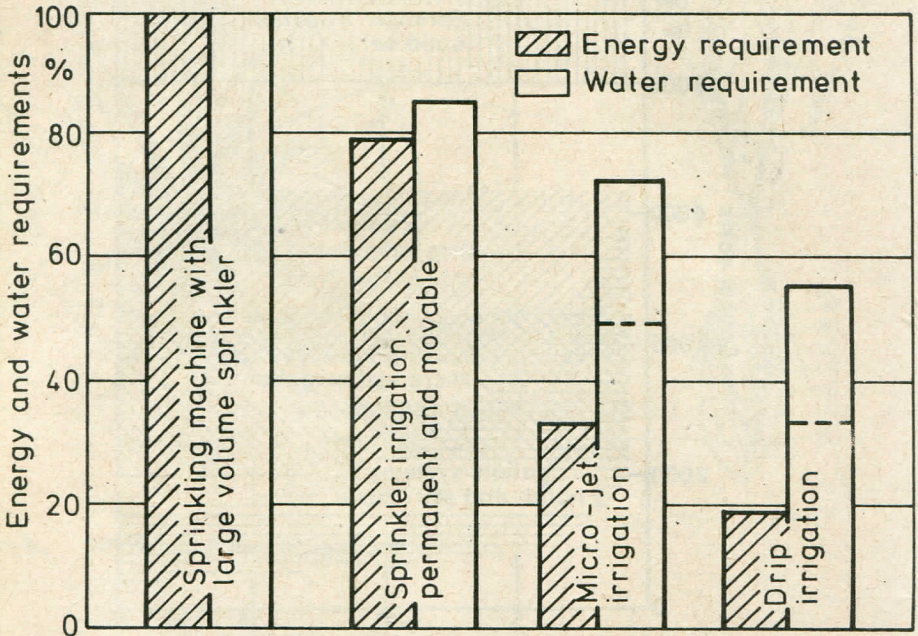

Figure 10. Equipment costs of irrigation systems

SUMMARY

In closing it can be stated that due to their optimal utilization of water and energy-saving distribution methods, drip and micro-jet irrigation systems will become increasingly important not only in arid regions but also in Central Europe, in particular in conjunction with special crops.

Industry is fully capable of manufacturing irrigation systems and equipment which function in difficult conditions. Science and industry must now concentrate on developing reliable and automatic systems.

REFERENCES

1. Ford, H.W. and D.P.H. Tucker, 1975. Blockage of drip irrigation filters and emitters by iron-sulfur-bacterial products. Hort. Science Vol. 10, s. 62/64
2. Ford, H.W. 1978. Bacterial clogging in low pressure irrigation systems. Irrigation Association /Technical Session. Cincinnati, Ohio, February 28
3. Gilaad, Y. and A. Marco, 1976. Erläuterung zur Bemessung von Drippern und Laterals. Israel center of water-works applicances. Tel Aviv
4. Goldberg, D. 1970. Increasing the agricultural use of saline water by means of trickle irrigation. Schrift zur 6. American Water Resources Conference, Las Vegas
5. Goldberg, D., B. Gornat and D. Rimon, 1976. Drip irrigation principles, design and agricultural practices. Drip Irrigation Scientific Publications, Israel
6. Gustafson, C.D. 1975. Drip irrigation — worldwide. Cooperative Extension, University of California, San Diego
7. I-Pai Wu and H.M. Gitlin, 1977. Drip irrigation systems design in metric units. Coop. Extens. Serv. Univ. of Hawaii Nr 144, s. 3/19
8. Karmeli, D. and J. Keller, 1975. Trickle irrigation design. Rain Bird Sprinkl. Mfg. Corp. Glendora/Calif.
9. Moser, E. and H. Sinn, 1978. Stromungstechnische Untersuchungen zur Berechnung von Tropfbewässerungsanlagen. Grundl. d. Landt. Nr 1, s. 18/25
10. Moser, E., H. Sinn, and B. Bernhardt, 1979. Ein Beitrag zur Verstopfung von Tropfbewässerungsanlagen. Wasserwirtsch. H.10, s. 312/15
11. Moser, E. and H. Sinn, 1980. Stromungstechnische Untersuchungen an Tropf- und Mikro-Jet-Bewässerungssystemen. Agrartechnische Berichte, H.12, s. 1/60
12. Rosegger, S., M.Dambroth, E. Siegert and F.P. Sorgel, 1976. Verfahren in der Tropfbewässerung. Ergebnisse über den Einsatz der Tropfbewässerung in Reihenkulturen. Zeitschr. für Bewässerungswirtschaft, H.1. s. 13/44.